

RSCD Qld BRANCH OPENING SOCIAL 2020

28th March, 2020, 1pm for 1.30pm

St Philip's Hall, Emperor St, Annerley

Music: Recorded

Cost: Qld Branch members FREE, non-members \$15

1. THE CLYDESID REEL (R32) Round The Room Commonwealth Games Ceilidh Dances Round the room dance, 2 facing 2

1- 8 All circle 4H round and back

9-16 All advance, Clap 4 times, Retire, Stamp 4 times

17-24 All dance RH Across, LH back

25-32 All set twice, clockwise facing couples make arch and all dance on/through to meet new couple

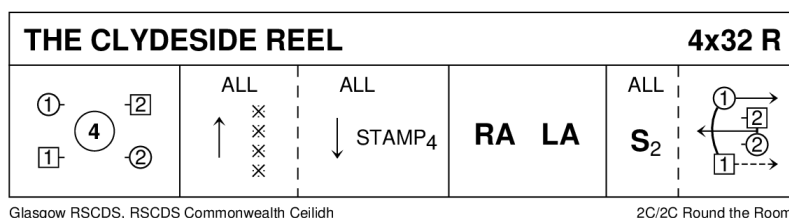

2. NEW YEAR JIG (J8x32) 3C (4C set) Maureen Robson RSCDS Book 51

1- 8 1s dance Fig of 8 on own sides (1s pass 2s RSh to start). 1L ends facing out

9-16 Reels of 3 on sides (1s+2s pass RSh to start). 1L end facing out

17-24 1L followed by 1M dances behind 2L, up between 2s, behind 2M, across set to 2nd place own side (2s step up 23-24)

25-32 1s+3s dance RH across. 2s+1s dance LH across. 1L finishes facing out, ready to start again

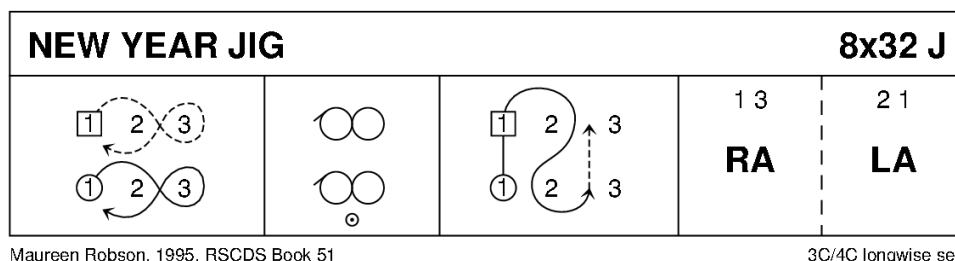

3. FAIR DONALD (S8x32) 3C (4C set) RSCDS Book 29

1- 8 1s dance down 1 place and cast up on own side to places, dance down 2 places and cast up on own side, into centre to face 1st corners

9-16 1s dance full diagonal Reel of 4 with 1st corners and pass partner LSh to face 2nd corners

17-24 1s dance full diagonal Reel of 4 with 2nd corners and end in centre facing up between 2s

25-32 1s cast to 2nd place and 2s+1s+3s set, 2s+1s+3s turn partners 2H. 213

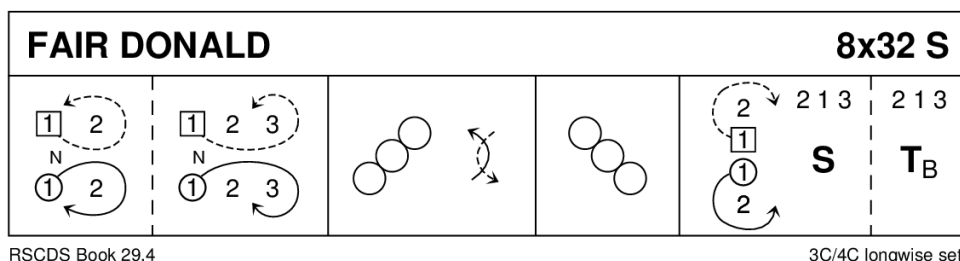

4. THE PIPE OPENER (J5x32) 5C set

Roy Goldring G and S Dances 3

1- 8 1s and 5s (ends) Adv&Ret diagonally, 1s cross RH and cast 2 places
 9-16 3s+1s+4s circle 6H round and back
 17-24 1s cross LH and cast down 2 places, 2s and 1s (ends) Adv&Ret diagonally
 25-32 All turn partner RH once round, LH once round

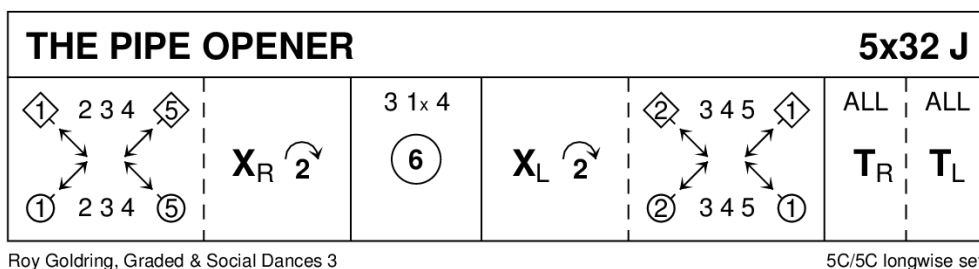

5. CORN RIGS (R6x32) 2C (3C set)

30 Popular Dances Bk1 / RSCDS Bk 4

1- 8 1s cast down own sides, turn inwards dance back to top
 9-16 1s dance full Fig of 8 round 2s
 17-24 1s lead down the middle and back
 25-32 1s+2s dance Poussette

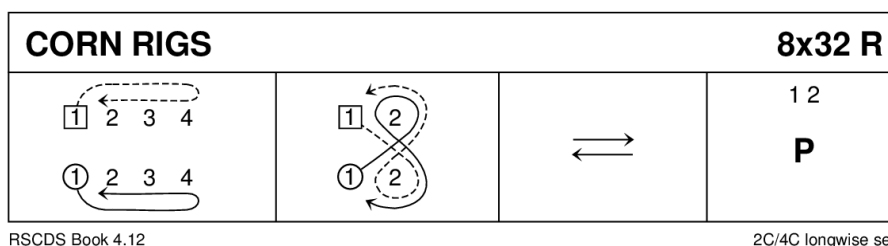

12 COATES CRESCENT (S4x32) 4C set

RSCDS Book 40

1- 8 All set on sides and cross RH, all set and cross back RH
 9-16 1s dance down to meet 4s who dance up and 1L+4L also 1M+4M dance out own sides, cast back to places and 1s lead down to 4th place (2s+3s+4s step up 15-16)
 17-24 3s+4s (middle couples) dance R&L
 25-32 2s+3s also 4s+1s dance RH across and LH back

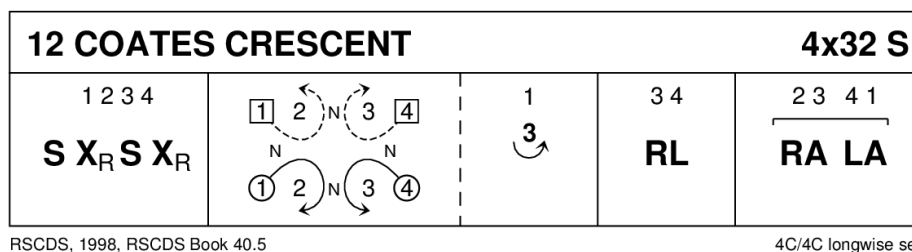

7. THE HIGHLAND RAMBLER (R8x40) 3C (4C set)

30 Popular Dances Bk 2 (Goldring)

1- 8 1s dance in and cast to 2nd place, dance RH across with 3s
 9-16 2s+1s dance LH across, 1L followed by partner cast up round 2L and dance down middle to 1L between 3s and 1M between 2s
 17-24 1s+2s+3s dance down the middle and back
 25-32 1M followed by partner cast down round 2L to 2nd places on own side and turn RH
 33-40 2s+1s+3s circle 6H round and back

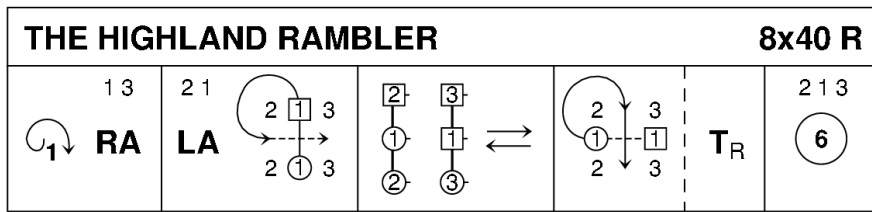

Roy Goldring, 1985, Leeds Silver Jubilee, RSCDS Thirty Popular Dances Vol 2

3C/4C longwise set.

8. SLYTHERIN HOUSE (S8x32) 3C (4C set)

Chris Ronald RSCDS Book 52

1- 8 1s+2s Set&Link; circle 4H round to Left. 213

9-16 1s pull back RSh and cast round 3rd corner (Man up/Lady down), pass LSh in centre and dance LSh round 1st corner (6 bars) 1s turn 3/4 LH to end in centre 1M below 1L, facing opposite sides

17-20 1L+2s and 1M+3s dance RH across

21-24 "Snake Pass":-

' 1L followed by 2L and 2M, 1M followed by 3M and 3L, pass LSh in the middle, dance out to the side, down to 3rd/up to 1st place, cross to own side and cast up/down to 2nd place in middle, RSh to RSh facing opposite sides

25-28 1M+3s (at top) and 1L+2s (at bottom) dance LH across

29-32 Repeat "Snake Pass" with dancers passing RSh in middle and all finish on sides. 213

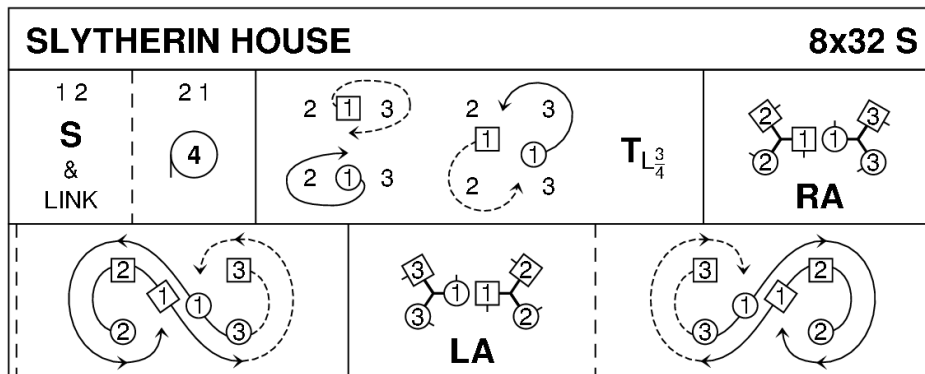

Chris Ronald, 2016, RSCDS Book 52.3

3C/4C longwise set.

9. PELORUS JACK (J8x32) 3C (4C set)

30 Popular Dances Bk 2 / Bk 41 (Skelton)

1- 8 1s cross RH and cast 1 place (2s step up 3-4), 1s dance RH across with 3s. 1s end with Man facing his 1st corner with his partner behind him

9-16 1s dance Alternating Tandem 1/2 reel of 3 with 1st corners to face Man's 2nd corner, 1s dance Alternating Tandem 1/2 reel of 3 with 2nd corners

17-24 1s dance Alternating Tandem 1/2 reels of 3 with Ladies' 1st corner (pstrn), 1s dance Alternating Tandem 1/2 reel with Ladies' 2nd corner (pstrn)

25-32 1M followed by partner dance into LH across with 2s, 1s retain LH and 1/2 turn to own sides and 2s+1s+3s set

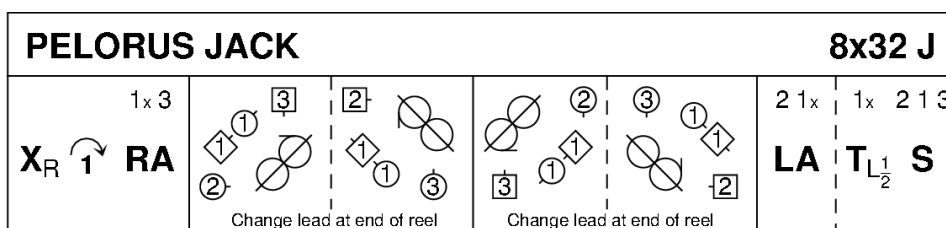

Barry Skelton, 1993, Dolphin Book, RSCDS Book 41.1, RSCDS Thirty Popular Dances Vol 2

3C/4C longwise set.

10. SHIFTIN' BOBBINS (R8x32) 3C (4C set)

30 Popular Dances Bk 2 (Ormskirk)

1- 8 1s cross RH to double triangle position with 2s+3s (1s step up) and set, 1s cast up to top and dance down until they are between 2s and 3s
 9-16 1L dances RH across with 2M+3M while 1M dances LH across with 2L+3L, 1s followed by 2s+3s dance down centre
 17-24 3s followed by 2s+1s dance up and 3s+2s cast down to places, 1L dances LH across with 2M+3M while 1M dances RH across with 2L+3L
 25-32 1s dance up to top and cast down to 2nd place opposite side, 1s dance ½ Fig of 8 around 2s to end in 2nd place on own sides. 213

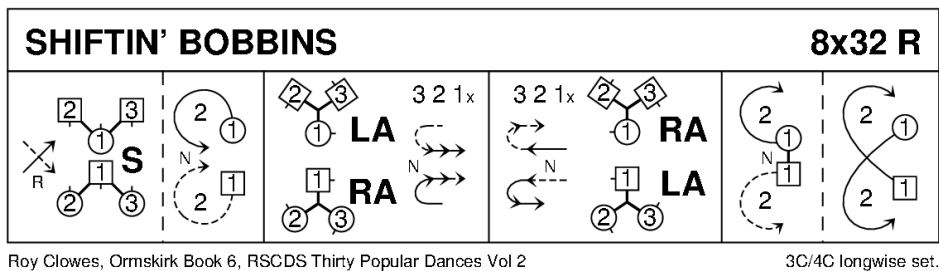

11. ASILOMAR ROMANTIC (S8x32) 3C (4C set) 30 Popular Dances Bk 2 (San Fransisco Coll 2)

1- 8 1s+3s dance double Fig of 8 around 2s, 1s crossing down, 3s cast up to start
 9-16 1s+2s dance Pousette
 17-24 1s dance in and down between 2s (2s step up), set to each other and dance RSh round 4th corner (1L up round 2L, 1M down round 3M), to face own 1st corner
 25-32 1s set to corners and partner ('Hello-Goodbye') ending with petronella turn to 2nd places. 213

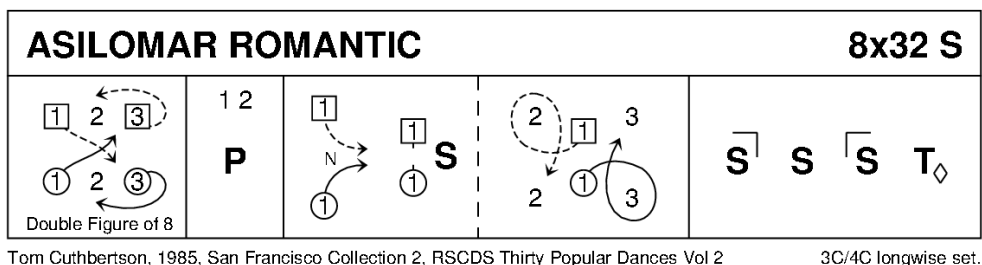

12. NAPIER'S INDEX (J8x40) 3C (4C set)

Brian Charlton RSCDS Book 45

1- 8 1s Set&Cast 1 place, turn LH 1¼ times to end in Balance-in-Line position between 1st corners
 9-16 1s+1st corners Balance-in-Line and turn corners RH (4 bars) to Balance-in-Line again with 1st corners
 17-24 1s dance reel of 3 on sides (LSh to 2nd corner) and end diagonally between 2nd corners (LH joined)
 25-32 1s+2nd corners Balance-in-Line and turn corners RH (4 bars), Balance-in-Line again with 2nd corners
 33-40 1s dance reels of 3 across (LSh to 3rd corners) and cross RH to 2nd places. 213

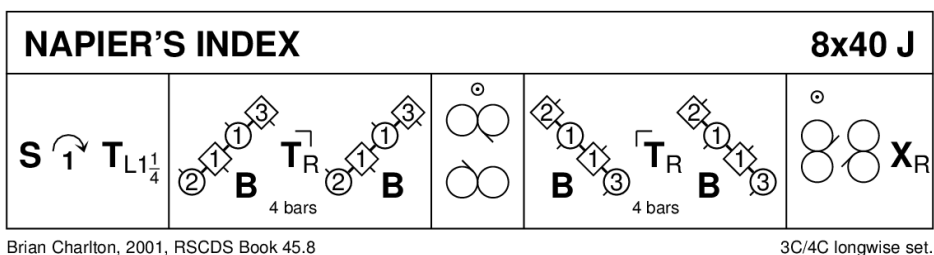

13. THE SINGING SANDS (S3x32) 3C set

Barry Priddey Silver Rose

1- 8 1s and 2s dance the Tourbillon:-

' 1s and 2s turn partners 2H ½ way, 1M and 2L lead partners on 1 place clockwise to end 1s on Ladies' side and 2s on Men's side, 1s set to 2s

' 1s and 2s ½ turn partners 2H, 1L and 2M lead partners on 1 place to end 2s in 1st place and 1s in 2nd place and 2s+1s cross RH to own sides

9-16 1s dance ½ Figs of 8 (Man round 2s and Lady round 3s), 1s dance ½ reels of 3 (Man with 3s and Lady with 2s)

17-24 1s dance diagonal R&L to end 312

25-32 All set and 3s+1s dance RH across ½ way at top while 2s cross RH (at bottom), all chase clockwise ½ way. 231

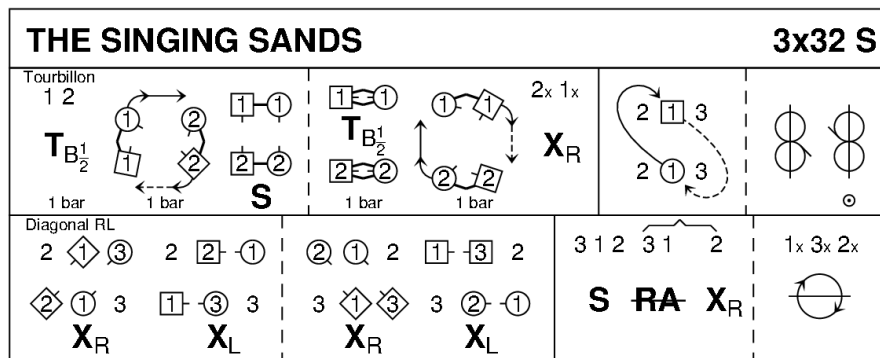

Barry Priddey, 1984, Silver Rose Book

3C/3C longwise set.

14. TRIP TO TIMBER RIDGE (R8X32) 3C (4C set)

Linda Henderson RSCDS Book 52

1- 8 1s turn RH, cast (2s step up) then 1L+2s and 1M+3s dance RH across. 1s end facing 1st corners

9-16 1s dance Corner Pass&Turn with 1st corners, pass RSh and repeat with 2nd corners. 1s pull back RSh to end BtoB in centre facing opposite sides

17-24 2s+1s+3s dance Double Triangles. Bars 23-24 1s petronella turn to 2nd place own sides

25-32 2s+1s+3s circle 6H round and back

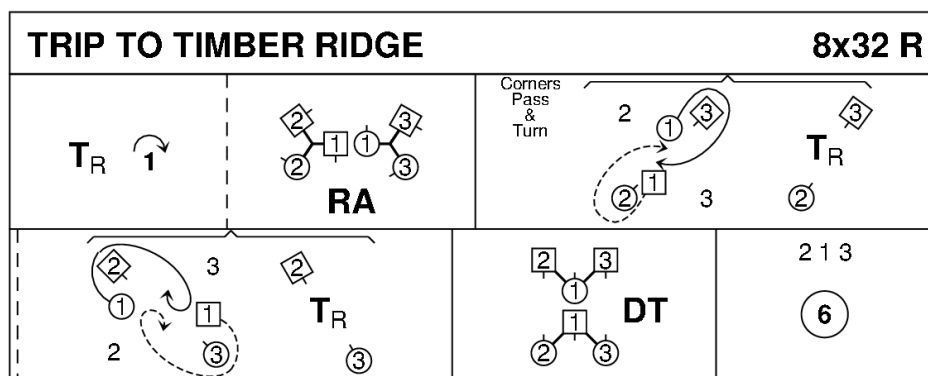

Linda Henderson, 2010, RSCDS Book 52.12

3C/4C longwise set.

15. MACDONALD OF THE ISLES (S3x32) 3C set Derek Haynes Carnforth Collection 2

1- 8 2s dance full diagonal Reels of 4 with 1st corners, passing by the LSh to face 2nd corners
 9-16 2s dance full diagonal Reel of 4 with 2nd corners to end in original places
 17-24 All dance Snowball Grand Chain for 3 couples:-
 ' 1s cross RH and change places LH on side with 2s
 ' 1s change places RH with 3s while 2s cross over RH at top
 ' 1s cross LH while 2s and 3s change places LH. 3(2)1
 25-32 3s+2s (at top) dance ½ R&L, 3s dance ½ Fig of 8 round end couples (3M up and 3L down)
 to end in 2nd places. 231

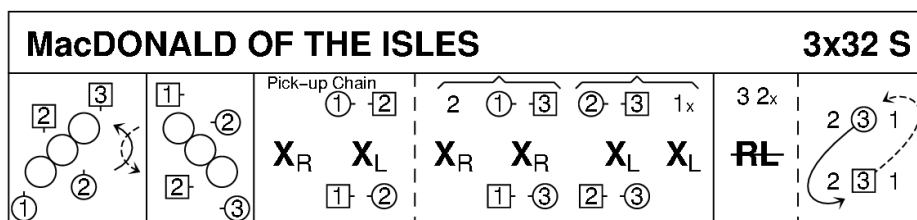

Derek Haynes, 1966, Carnforth Collection 2, RSCDS Thirty Popular Dances Vol 2 3C/3C longwise set.

16. THE LAIRD OF MILTON'S DAUGHTER (J8x32) 3C (4C set) Lord Craigmyle RSCDS Bk 22

1- 8 1s set, cross RH, cast 1 place and turn LH to face 1st corners
 9-24 1s dance Corner Chain with 1st and 2nd corners:-
 ' 1s change places RH with 1st corners, 1st corners turn LH in centre and return to places giving RH to 1s who turn LH in centre to face 2nd corners
 ' 1s change places RH with 2nd corners, 2nd corners turn LH in centre and return to places giving RH to 1s and 1s end with a ½ turn LH to 2nd place own sides
 25-32 2s+1s+3s circle 6H round and back

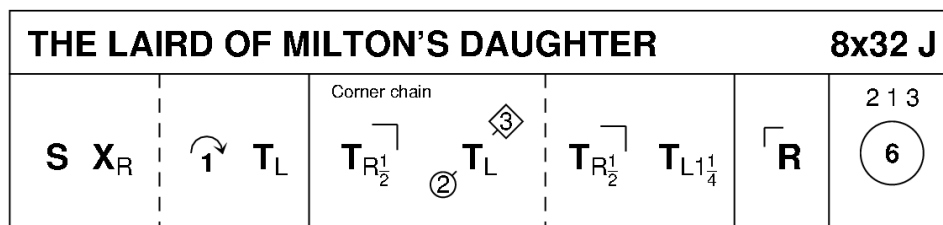

Lord Craigmyle, RSCDS Book 22.10 3C/4C longwise set.

(MINICRIB, Dance Crib compiled by Charles Upton, Deeside Caledonian Society, and his successors)

Please bring a small plate of goodies to share for High Tea.

You may pay your Qld Branch membership on the day for free admission.